

CESCO chain conveyors are designed with flexible concept and modular design, for horizontal or slightly inclined conveying of cereals, meals, pellets, and granular products in general. They realise the completely closed conveying of the product, with capability to load and unload the product, even in reversible mode, in several points, with zero loss during the conveying, easy cleaning, maintenance, and safety during operation thanks the complete bolted system used.

They are designed with particular attention to the shape of the internal part of the casing, in order to limit the wear, extend the life of the machine and prevent deposit of product at the end of the conveying operation.

### GENERAL CHARACTERISTICS

- Drive and tail stations with rounded shape.
- Tail station equipped with screw chain adjustment and spring-loaded length and shock absorber.
- Chain sprocket bolted to the shaft and divided in 2 parts for easy maintenance.
- Chain flights equipped every 3 m with UHMW-PE scrapers.
- Supports of both the drive and the tail shaft completely external allowing easy bearing maintenance.

### Technical data

Capacity		CC200	CC300	CC340	CC420
(Bulk density 750 kg/m <sup>3</sup> )	Nominal	50 t/h	100 t/h	150 t/h	200 t/h
	Maximum	60 t/h	130 t/h	200 t/h	250 t/h
Maximum length	Standard	60 m			
	Optional	80 m			
Drive unit		Right angle gearmotor with backstop			
Chain speed		Up to 0.60 m/s			
Chain type acc. DIN8167		M56	M112	M160	M160
Sound pressure level		Up to 75 dB(A)			
Operating conditions		-15°C to +40°C ambient			

### Materials

Casing	Standard	Pre-galvanised high tensile steel S235 Z450
	Optional	Pre-galvanised S235 Z600 Hot-dip-galvanised S235 Z900 Stainless steel Painted steel
Wear resistant lining, bottom	Standard	UHMW-PE, antistatic, 10 mm
	Optional	Hardox® steel, 4 mm
Wear resistant lining, sides	Standard	UHMW-PE, antistatic, 4 mm
	Optional	Hardox® steel, 4 mm
Chain		Steel, oil coated
Rollers on return		Steel, oil coated
Scraper flaps		UHMW-PE, antistatic, 3 mm
Sensors	Standard	Overflow sensor Rotation sensor
	Optional	Bearing temperature sensor
ATEX	Standard	Zone 21 inside / ATEX free outside
	Optional	Zone 21 inside / Zone 22 outside
Optional accessories		Outlet chute Inlet chute for vertical inlet Lateral self-dosing inlet Top cover for spot filters or dust aspiration chute Electrical / pneumatic / manual slides Return buckets Inspection window Supporting legs Double bottom casings Reversible drive system

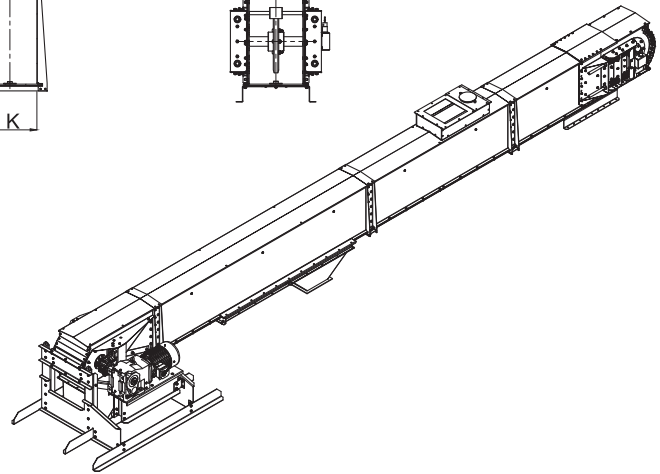
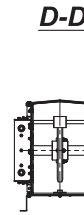
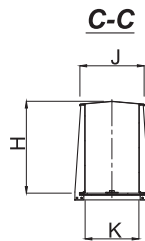
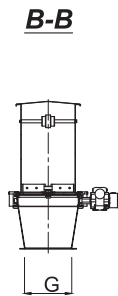
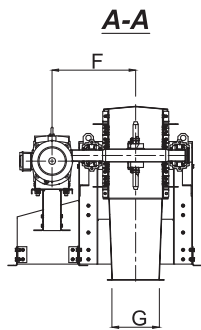
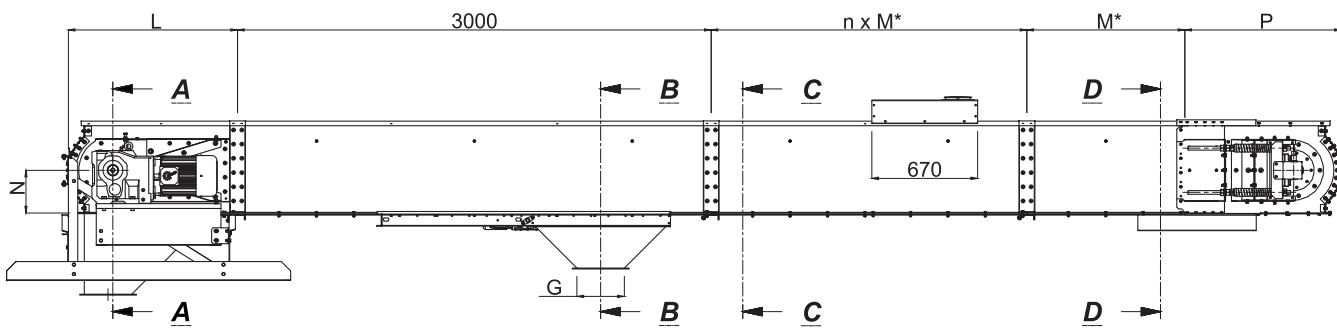

Type	F mm	G mm	H mm	J mm	K mm	L mm	N mm	P mm
CC 200	270	200x200	333	260	185	782	140	992
CC 300	510	250x250	469	364	300	952	185	992
CC 340	530	300x300	580	353	340	1072	270	992
CC 420	560	350x350	580	478	415	1072	270	992

M\* = The casing can be 500 mm, 1000 mm, 2000 mm or 3000 mm long