



The CESCO Corrugated Square Silo (CSS) is a modular, efficient, and versatile storage system designed for the safe and well-organized storage of bulk materials, including grains, corn, pellets, and other granular and free-flowing bulky products.

CESCO's versatile square silos help address space limitations and seismic challenges in process plants, thereby enhancing safety and cost-efficiency, especially during facility expansions.

ADVANTAGES

- Compact and modular design utilizing fully bolted technology for simplified erection and transport.
- Up to 38% higher storage capacity compared to round silos.
- The absence of gaps between silos eliminates residual spaces, reducing the risk of mold, fungi, or insect contamination.
- fully bolted design: materials are well packed, reducing shipping volume and costs, while allowing for easy and cost-effective on-site assembly.
- Exceptional corrosion resistance achieved through comprehensive coating of cavities in the double-walled components.

DESIGN

- Cell lengths range from 2000 mm to 4000 mm in 250 mm increments.
- Cell heights range from 3 to 30 m in 550 mm increments.
- Cell wall width available in thicknesses of 120 mm and 160 mm.
- Corrugated sheet's inclination and wide bevels ensure a smooth product flow, preventing any product deposition.
- Outer walls of the cells designed for cladding attachment using sheet metal or polyurethane sandwich panels.
- Cell outlet hopper with a central round outlet, or multi-hopper.
- Includes substructure, frame, ladders, and operating platforms.
- Multiple coating options are available, including paint, galvanization, or stainless steel materials for both internal and external surfaces.

Principle of operation



The silo cells in the modular design can be configured either as a silo battery in a row or as a block with varying heights and capacities. The silo block can seamlessly integrate into the steel structures of machine houses or mill buildings.

Each silo is composed of double-wall elements that are securely screwed together. Each wall element features a lateral structure forming a quarter beam. When four double-wall elements come together, they create a hollow beam, which can be filled with concrete after installation to ensure the silo's high rigidity.

In addition, each silo cell is equipped with a bolted outlet hopper, providing both central round and multi-hopper outlet options.



- 1 Single bin
- 2 Corner column
- 3 Wall column
- 4 Central tronco-conical hopper
- 5 Multi hopper
- 6 Supporting structure
- 7 Wall cladding
- 8 Roofing
- 9 Machine house

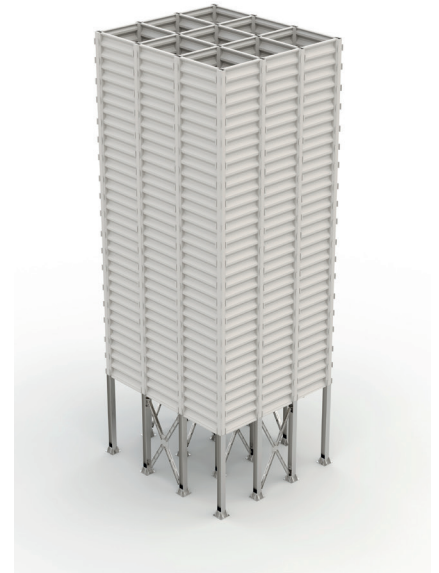
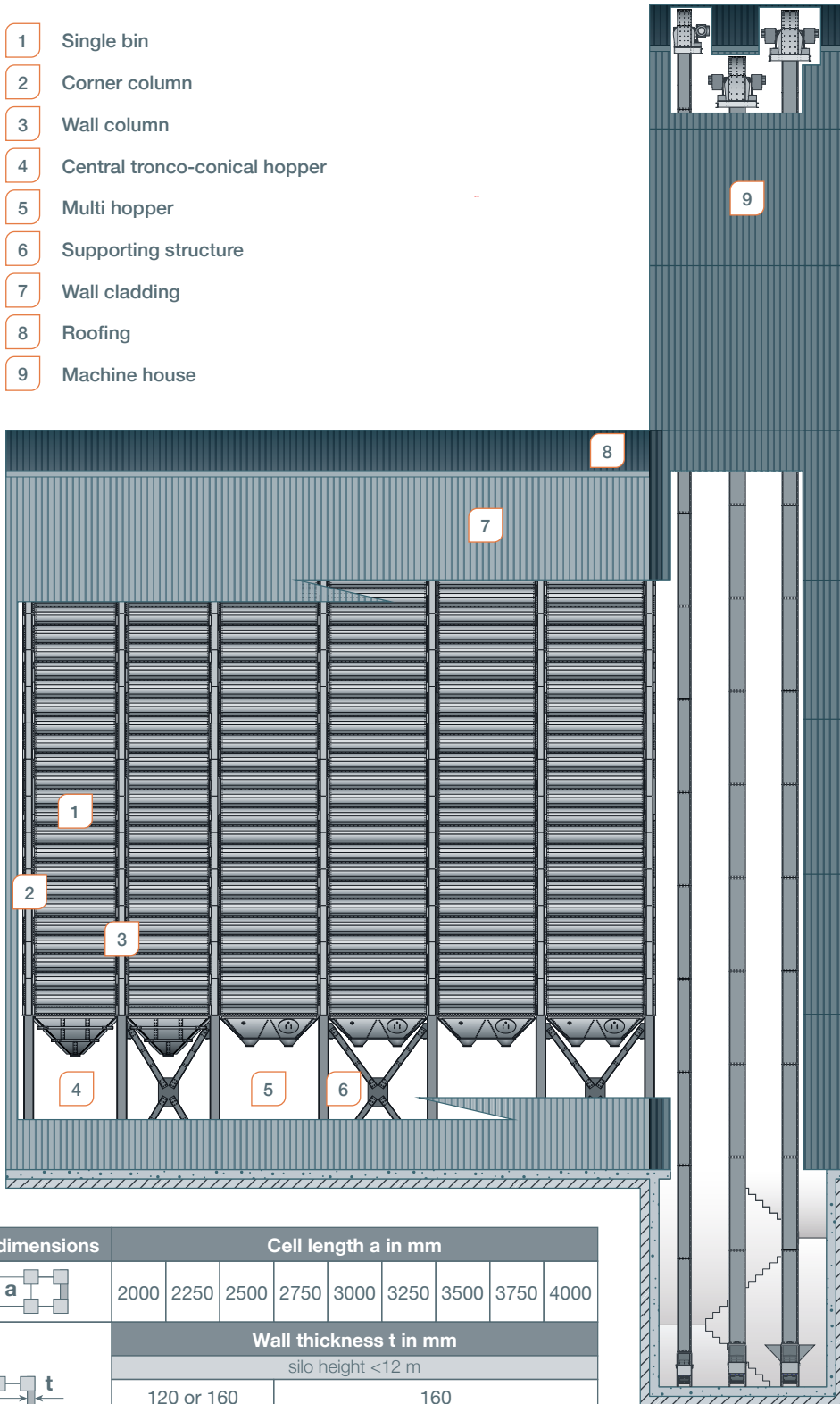

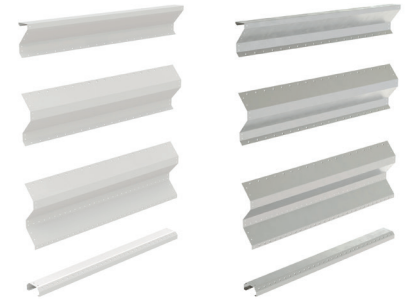

Compact 3x3 silo cell with supporting structure. The roof of the cells can be constructed either with a reinforced concrete cover cast on a corrugated galvanized steel sheet bed or using a globular sheet cover and a lightweight beam network.

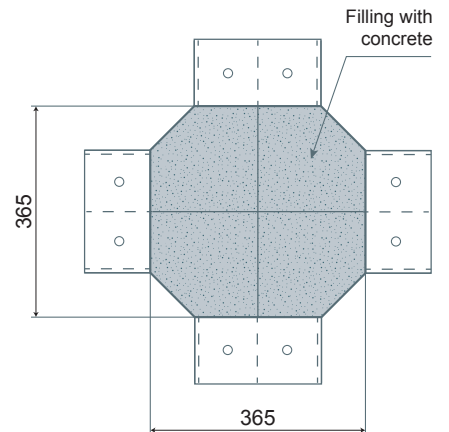

CSS wall elements available with either painted or galvanized surface coating.



Horizontal cross section of internal column.

Cell dimensions	Cell length a in mm								
	2000	2250	2500	2750	3000	3250	3500	3750	4000
	Wall thickness t in mm								
	silo height <12 m								
	120 or 160			160					
	silo height >12 m								
	160								